

# HESTIA + CONDOR

A groundbreaking model of light and compact proportions. Fitted with a mini reflector the Hestia combines a high photometric performance with sleek aesthetics. For mounting heights from 5m up to 12m.

## PRODUCT GALLERY

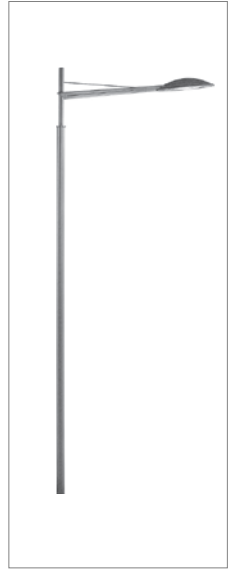
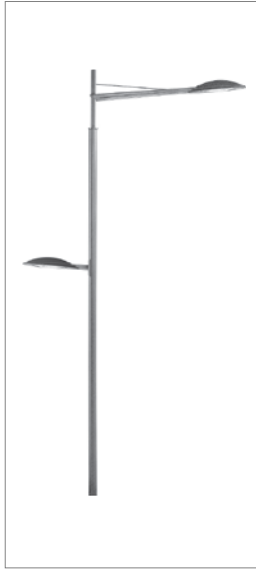

# HESTIA + CONDOR

## DESCRIPTION

Designed by Elizabeth de Partzamparc the combination of the Condor column and bracket with a choice of mini or midi sized Hestia luminaire creates a sleek and compact impression.

### Mounting Details

- Hestia Mini or Midi: side entry mounted on a 34mm diameter bracket arm with 85mm penetration. Locking by two grub screws. For flush fitting bracket appearance use 60mm diameter bracket arm with 34mm diameter spigot, length 85mm.
- Condor: 5-12m tapered conical column with optional rear bracket: root or flange mounted. Wall bracket: flange mounted, direct fix.

### Lamp options

Hestia Mini

- 35W, 70W, 100W & 150W Ceramic Metal Halide,
- 50W & 70W High Pressure Sodium.
- 45W, 60W, 90W & 140W CosmoPolis.

Hestia Midi

- 100W, 150W & 250W Ceramic Metal Halide.
- 100W, 150W & 250W High Pressure Sodium.
- 90W & 140W CosmoPolis.

### Control gear & Photocell options

- Control gear: Located in luminaire body mounted on gear tray. Tool free access by quarter turn compression fastener allowing lower body of luminaire to hinge down.
- Photocell option: Miniature photocell fitted to upper body casting with water tight gasket and wired to lantern control gear. 70 lux as standard.

### Optics

Hestia Mini

- Reflector type 1914 (mini-reflector), with low profile glass. Flat glass available up to 70W.
- Reflector type 1659  $\mu$ R® (micro-reflector) with low profile glass.

Hestia Midi

- Reflector type 1627, with flat glass or low profile glass.

### Photometric Centre

Distance from back of lantern to photometric centre

- Hestia Mini: 0.5m
- Hestia Midi: 0.6m

### Materials

- Luminaire body: die-cast aluminium alloy.
- Luminaire protector : tempered glass
- Column & bracket: galvanised mild steel. Aluminium or stainless steel available on request
- Colour: AKZO grey 900 sanded. Other colours available on request.

### Protection class (IP)

- Optical compartment: IP66 Sealsafe®
- Luminaire body: IP44 (minimum IP65 option available)

### Electrical Class & Nominal Voltage

- Class I or II (option) / 230V 50Hz

### Impact resistance

- IK08

### Indicative Maximum Weight (including lamp & control gear)

- Hestia Mini 70W: 7.4kg
- Hestia Mini 150W: 8.4kg
- Hestia Midi 100W: 10.0kg
- Hestia Midi 150W: 10.9kg
- Hestia Midi 250W: 11.8kg

### Maximum wind load area

- Hestia Mini: 0.0826m<sup>2</sup> (low profile glass)
- Hestia Midi: 0.109 m<sup>2</sup> (flat glass)
- Hestia Midi: 0.118m<sup>2</sup> (low profile glass)

### Standards/Norms

- EN60598/EN62262

# HESTIA + CONDOR

## DIMENSIONS

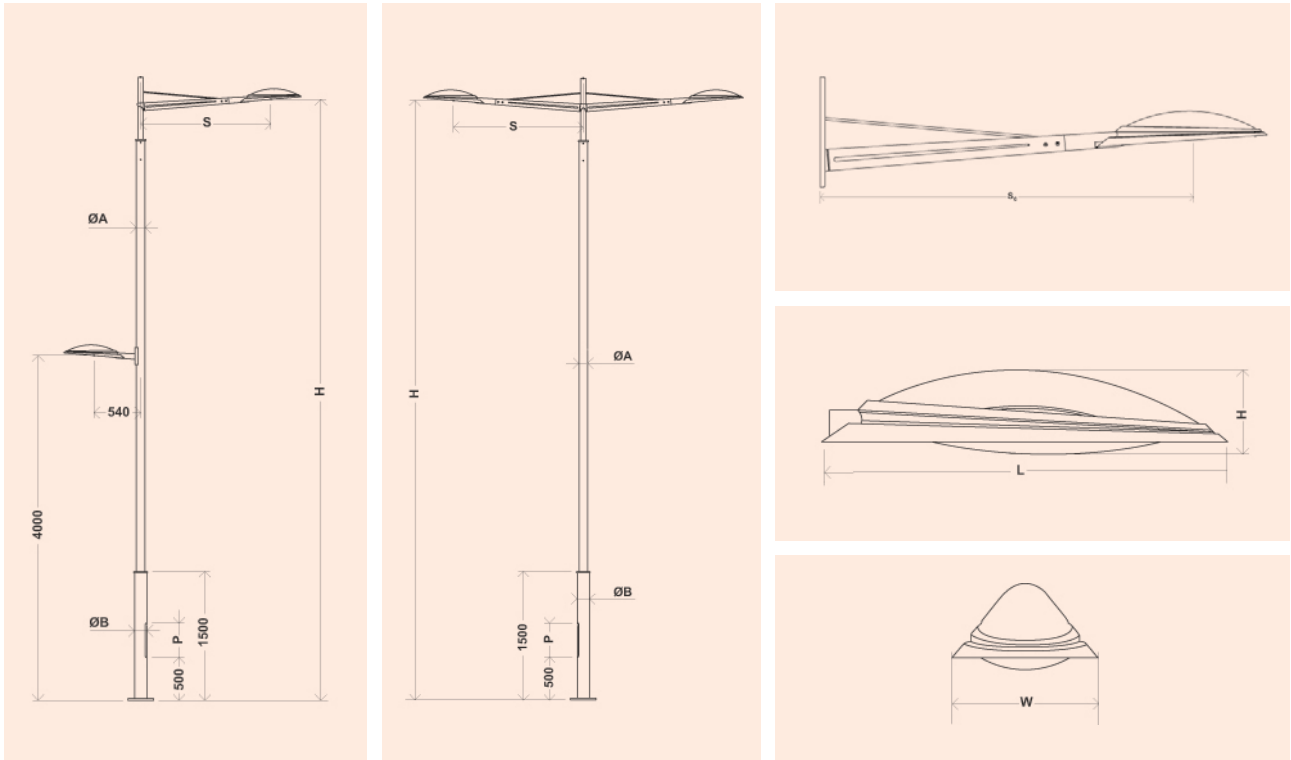

	S	Sc	ØA	ØB	H	P
Hestia Mini	1510 mm	1515 mm	100 mm	140 mm	5 > 8 m	500 x 90 mm
Hestia Midi	1645 mm	1650 mm	100 mm	140 mm	5 > 8 m	500 x 90 mm
	2145 mm	–	140 mm	195 mm	6 > 12m	500 x 110 mm

## LIGHT DISTRIBUTION

